



SOLINTEG SMART METER

RMM/RMK series



User Manual

ENGLISH VERSION



1	About This Manual	4
	1.1 How To Use This Manual.....	4
	1.2 Target Groups	4
2	Safety Instructions	5
	2.1 Safety Notes	5
	2.2 Statement	5
3	Product Description.....	6
	3.1 System Introduction	6
	3.2 Product Appearance	7
	3.3 System wiring	10
	3.4 Storage	10
4	Installation	11
	4.1 Smart Meter	11
	4.2 Current Transformer.....	11
5	Wiring Connection	12
	5.1 AC Connection	12
	5.2 RMM connected with MHT/MHS series	13
	5.3 RMM connected with OGT series	14
	5.4 RMK connected with OGT/OGS series	14
6	Commissioning	16
	6.1 Meter Configuration Table	16
	6.2 RMK Network Configuration	16
7	Operating Instruction	17
	7.1 Screen Introduction	17
	7.2 Key Introduction	18
	7.3 Display Interface	19
	7.4 Parameter Setting Interface	20
	7.5 RMK WIFI Configuration	21
8	Appendix.....	22
	8.1 Technical Parameters	22
	8.2 Contact Information.....	23

1 About This Manual

This manual is an integral part of Solinteg RMM/RMK smart meter. It mainly introduces the assembly, installation, electrical connection, debugging of the products.

The products, services or features purchased are subject to the commercial contracts and terms of Solinteg Power Co., Ltd. All or part of the products, services or features described in this document may not be within the scope of purchase. This document serves only as a guide to use, and all statements, information and recommendations in this document do not constitute any express or implied guarantee.

1.1 How To Use This Manual

Before installing and using meters, please read this manual carefully, understand the safety information and be familiar with the functions and characteristics of inverters.

The manual content of subsequent versions of the inverter may be subject to change. The latest manual can be found at www.solinteg.com.

1.2 Target Groups

This manual is applicable to the electrical installers with professional qualifications and end-users, who should have the following skills:

- ① Training for installation and commissioning of electrical system, as well as dealing with hazards.
- ② Knowledge of the manual and other related documents.
- ③ Knowledge of the local regulations and directives.

2 Safety Instructions

2.1 Safety Notes

- ① Before installation, please read this manual carefully and follow the instructions in this manual strictly.
- ② Installers need to undergo professional training or obtain electrical related professional qualification certificates.
- ③ Apart from performing work at the wiring terminal (as instructed in this manual), touching or changing components without authorization may cause injury to people, damage to inverters and annulment of the warranty.
- ④ All electrical installations must conform to local electrical safety standards.
- ⑤ If the meter needs maintenance, please contact the local designated personnel for system installation and maintenance.

2.2 Statement

Solinteg Power Co., Ltd. has the right not to undertake quality assurance in any of the following circumstances:

- ① Damages caused by improper transportation.
- ② Damages caused by incorrect storage, installation or use.
- ③ Damages caused by installation and use of equipment by non-professionals or untrained personnel.
- ④ Damages caused by failure to comply with the instructions and safety warnings in this document.
- ⑤ Damages of running in an environment that does not meet the requirements stated in this document.
- ⑥ Damages caused by operation beyond the parameters specified in applicable technical specifications.
- ⑦ Damages caused by unauthorized disassembly, alteration of products or modification of software codes.
- ⑧ Damages caused by abnormal natural environment (force majeure, such as lightning, earthquake, fire, storm, etc.).
- ⑨ Any damages caused by the process of installation and operation which don't follow the local standards and regulations.
- ⑩ Products beyond the warranty period.

3 Product Description

3.1 System Introduction

RMM/RMK series are smart meters and support different voltage levels and power grid. The RMM/RMK can collect the data in real time, including grid voltage, current, power and energy yield. By cooperating with Solinteg monitoring system, RMK can realize real-time monitoring of load consumption.

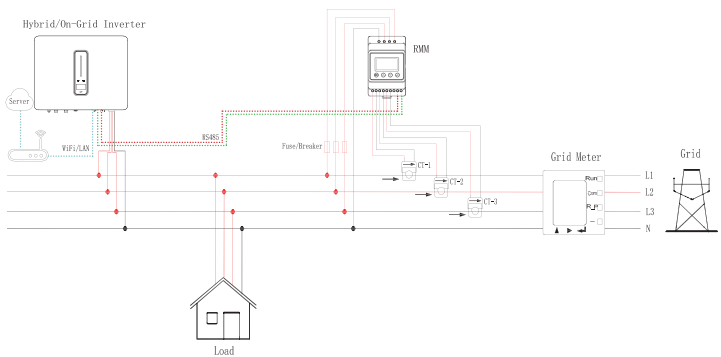

Figure 3-1 RMM connected with Solinteg inverter

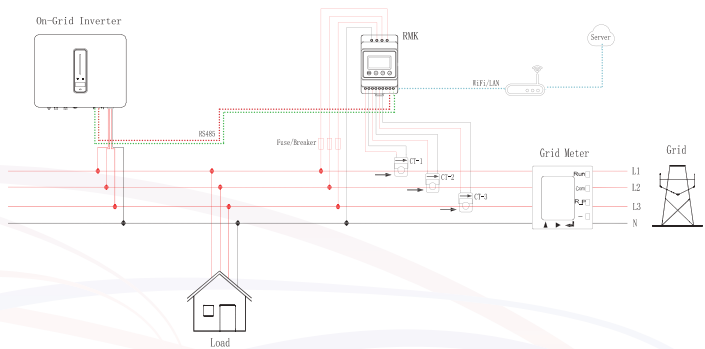

Figure 3-2 RMK connected with Solinteg inverter



More application scenarios of RMM/RMK are still under development, please contact Solinteg for details.

3.2 Product Appearance

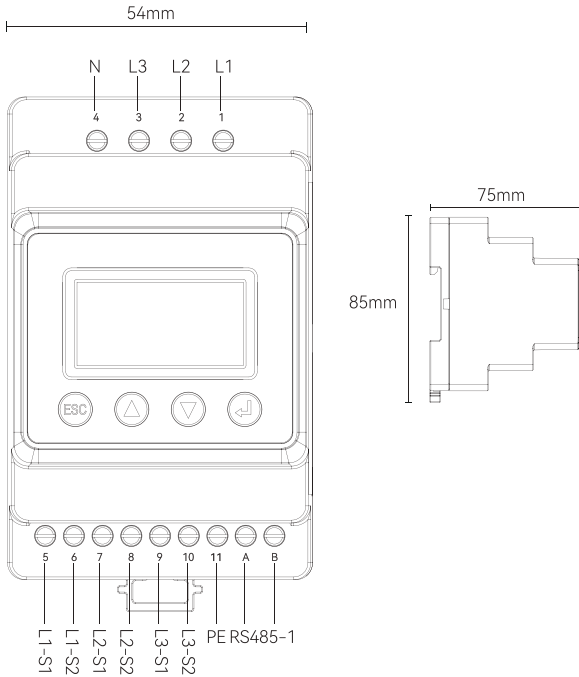
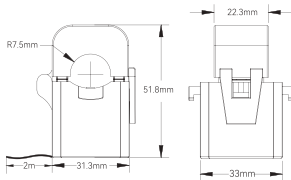

Figure 3-3 Smart Meter Appearance

Wiring terminals as shown in the table below.

No.	Definition	Function
1	L1	L1/L2/L3/N connect to grid to detect power grid voltage.
2	L2	
3	L3	
4	N	
5	L1-S1	To detect the CT current and direction.
6	L1-S2	
7	L2-S1	
8	L2-S2	
9	L3-S1	
10	L3-S2	
11	PE	Ground Connection
	RS485-1	RMK, communicate with single-phase and three-phase PV grid-connected inverter. RMM, communicate with three-phase PV grid-connected inverter.
	RS485-2	RMM, communicate with hybrid inverter.
	ANT	WIFI antenna port. RMM doesn't have this port.
	LAN	LAN communication port. RMM doesn't have this port.
	Type-C	Specified Debug Interface. Do not use it by non-professionals

CT Appearance



Ø16 120A

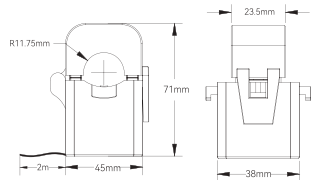

Ø24 200A

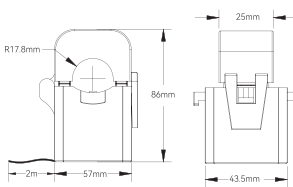

Ø35 300A



NOTE

The RMM-MA / RMK-MA will be delivered with matched CT(s) supplied are calibrated and tested to be used with the device in this package. These CT(s) cannot be interchanged within the same device and cannot be used for other devices from other packaging.



NOTE

The RMM-5A / RMK-5A is not delivered with CT. Customers are required to purchase qualified standard CT with secondary side output of 5A, CT accuracy of 0.5, and maximum CT conversion ratio of 5000:5.

3.3 Packing list

Grid Type	Rated Voltage	CT Number	Note
1	RMM or RMK	1pcs	/
2	CT	1-3pcs	Only MA Version
3	WIFI ANT	1pcs	Only RMK
4	Cord end terminal	12pcs	/

3.4 Storage

- ① Do not dispose of the original packing case. It is recommended to store the device in the original packing case when the device is decommissioned.
- ② The storage temperature and humidity should be in the range of $-30^{\circ}\text{C}\sim+60^{\circ}\text{C}$, and less than 90%, respectively.

4 Installation

Solinteg RMM/RMK series is IP20 and can be installed indoors only.

4.1 Smart Meter

- ① Pull to release the retaining clip.
- ② Mount the meter on the track and push the Retaining clip up (a click sound indicates it is installed well).

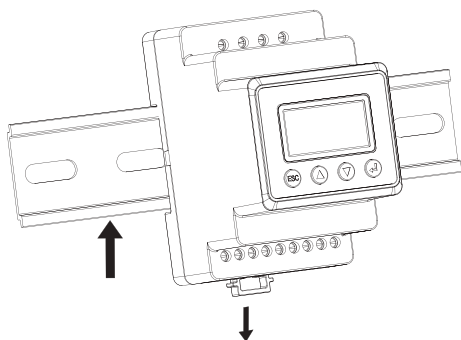
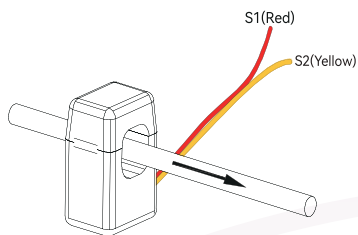

Figure 4-1 Smart Meter

4.2 Current Transformer



NOTE

The installation direction of the CT varies according to the application scenario. Please follow the directions of the CT as shown in 3.1 System Introduction

Incorrect connection or direction will cause incorrect data.

5 Wiring Connection

5.1 AC Connection

The installation of the meter should be strictly in accordance with the instructions of the User Manual, otherwise the meter may not work properly. According to different application scenarios, the meter wiring is different, and the meter used is also different. Please select the appropriate meter according to the use scenario.

Please follow the system wiring as shown in 3.1 System Introduction.

The RMM/RMK supports three-phase grid(with 3 CTs) , single-phase grid(with 1 CT), and other grids.

Grid Type	Rated Voltage	CT Number	Note
Single-phase	110/120/127/(L-N) 220/230/240V(L-N)	1*CT	L/N/PE
Three-phase	380/400V/415V(L-L) 208/220/240V(L-L)	3*CT	Wye (3L/N/PE) Delta (3L/PE)

The following is a list of common terminal connection diagrams. Select a proper system schematic diagram based on the actual situation. For different solutions, contact Solinteg for technical support.

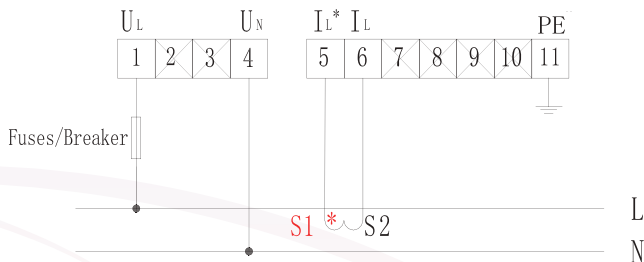

Figure 5-1 Single-phase

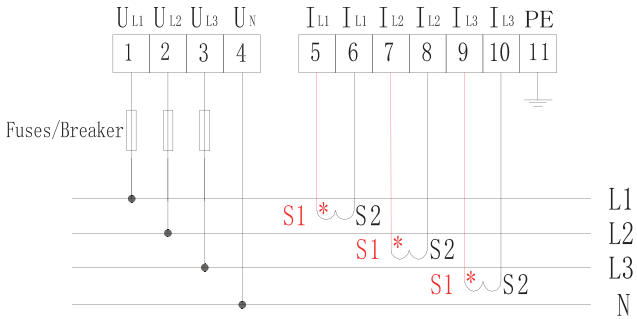

Figure 5-2 Three-phase(Wye)

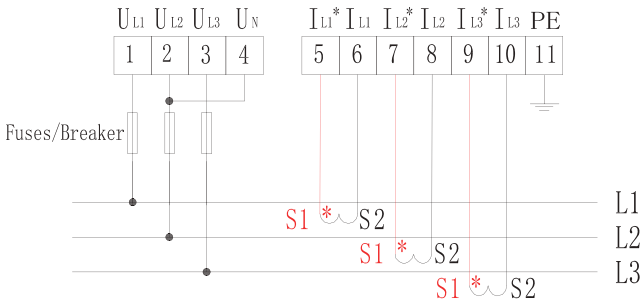

Figure 5-3 Three-phase (Delta)

5.2 RMM connected with MHT/MHS series

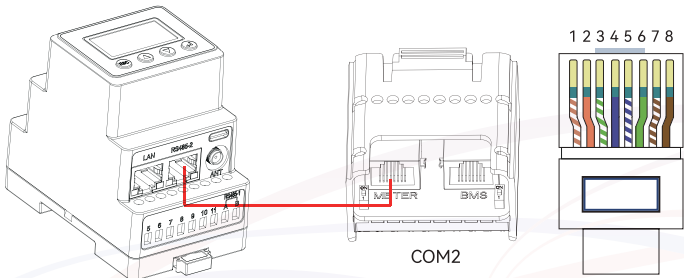

Figure 5-4 RMM connected with Solinteg Hybrid inverters

No.	Color	Definition	No.	Color	Definition
1	Orange & White	/	5	Blue & White	/
2	Orange	/	6	Green	/
3	Green & White	/	7	Brown & White	RS485_B2
4	Blue	/	8	Brown	RS485_A2

Figure 5-5 RJ45 terminal connection sequence and definition

5.3 RMM connected with OGT series

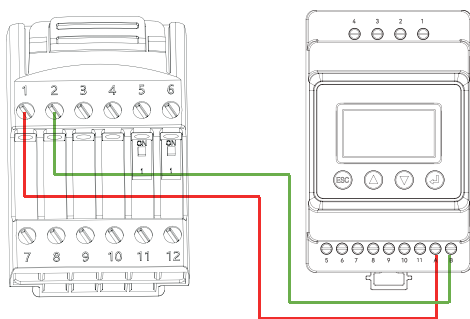

Figure 5-6 Extended version inverter

5.4 RMK connected with OGT/OGS series

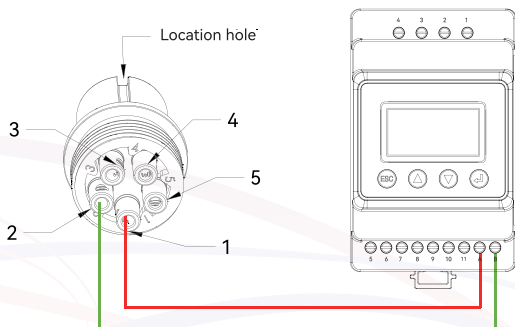

Figure 5-7 Basic version inverter

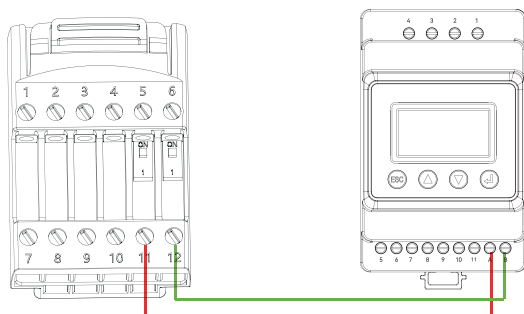

Figure 5-8 Extended version inverter



NOTE

When the RMM is connected to the MHT/MHS/OGT series inverter. The Modbus address of the RMM must be 1. If the communication between RMM inverter fails, please check the Modbus address of the RMM.



NOTE

When the RMK is connected to OGT/OGS series inverters.

- ① The inverter does not need to be connected to the network, and RMK is configured to connect to the network.
- ② The Modbus address of the inverter must be 247. If the communication between RMK and inverter fails, please check the Modbus address of the inverter.

6 Commissioning

6.1 Meter Configuration Table

	LAN/WiFi	DHCP	CT Ratio	Grid Type
RMM-MA	---	---	---	○
RMK-MA	●	○	---	○
RMM-5A	---	---	●	○
RMK-5A	●	○	●	○

● : Need/Suggest to be configured

○ : Whether to configure it according to site actual requirement

---: No this option

Generally, Modbus and Time do not need to be set.

6.2 RMK Network Configuration

- ① First select the network mode in Comm Set-Connect Type;
- ② If you select the Wifi network mode, please configure the wifi parameters according to the 7.5 Wifi Configuration. If you choose LAN networking mode, skip this step.
- ③ Check if the DHCP of router is enabled.If DHCP is enabled on the router, the DHCP/IP Addr/Gateway Addr/ Subnet Mask/ DNS Addr does not need to be configured. Otherwise, they will need to be configured on RMK screen.

7 Operating Instruction

7.1 Screen Introduction

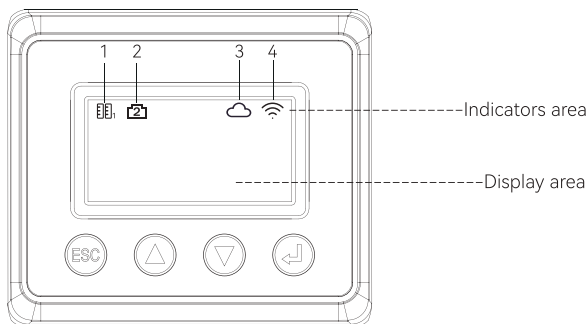

Item	Indicator	Status	Description	
1		RS485-1	Always On	Communicate with inverter normally
			Off	Disconnection
2		RS485-2	Always On	Communicate with inverter normally
			Off	Disconnection
3		Network status	Slow flashing	The meter is not connected to the router.
			Quick flashing	The meter is connected to the router but not connected to the server.
			Always On	Communicate with the server normally
4		LAN	Always On	The communication method is selected as LAN in display
			Off	The communication method is not selected as LAN in display
		WiFi	Slow flashing	The communication method is selected as WiFi in display
			Off	The communication method is not selected as WiFi in display

7.2 Key Instructions



key



key



key



key

Key	Function
	Under the setting page, press this key to return to the upper menu
	Under Display interface, press this key to move the cursor to the upper part; Under Setting interface, press this key to toggle level menus or increase the value
	Under Display interface, press this key to move the cursor to the down part; Under Setting interface, press this key to toggle level menus or decrease the value
	Under Display interface, press this key to enter the password page for parameters setting; Under Setting interface, press this key to confirm the selection of the items and modification of parameters.

7.3 Display Interface

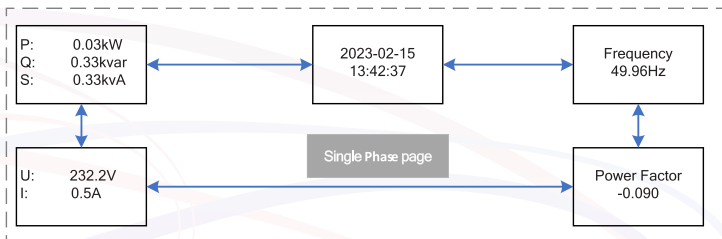

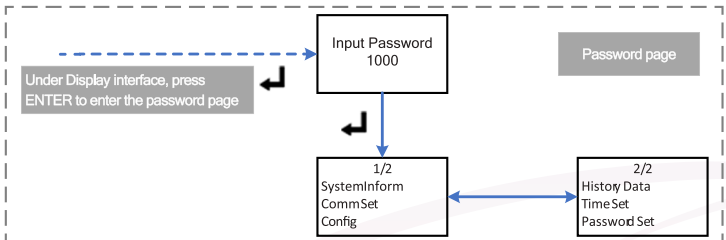
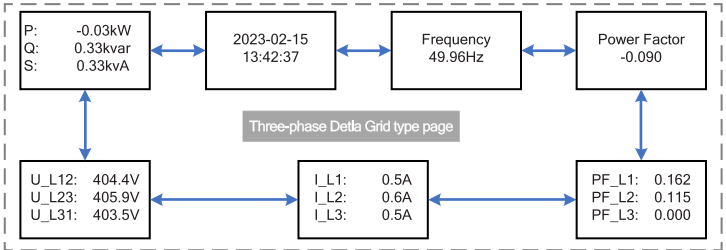
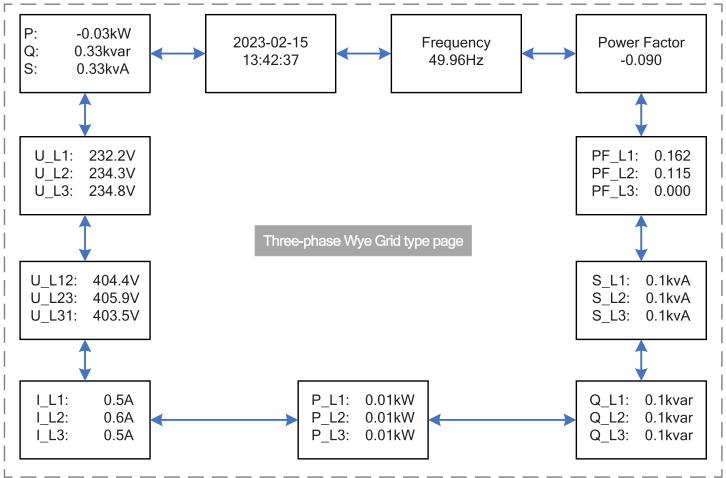

7.4 Parameter Setting Interface

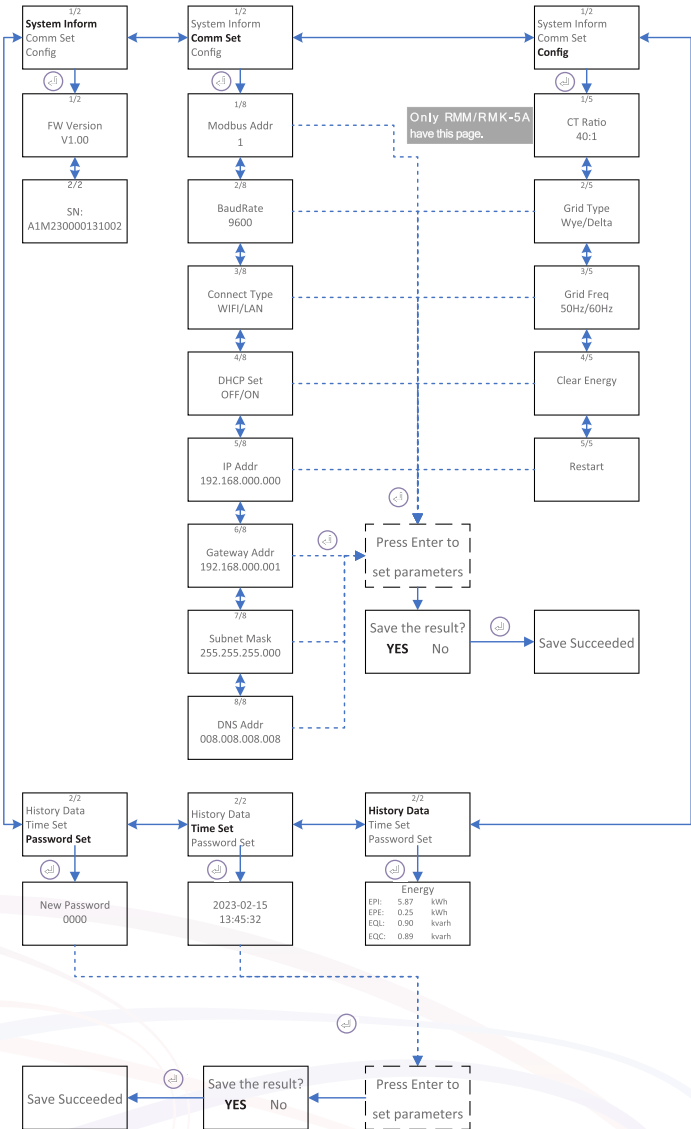

7.5 RMK WIFI Configuration

- ① Prepare a laptop or Smartphone and turn on the WLAN connection.
- ② Searching for the corresponding WLAN in the WLAN connection list “WIFI-AP*****” (*represents the last 8 numbers of the inverter SN), and tap connect.
- ③ Open the browser and enter 10.10.100.254.
- ④ Tap “Scan”, A list of WiFi network names pop up.

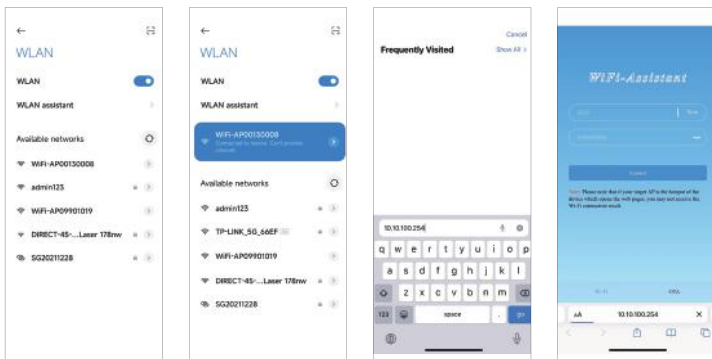

- ⑤ Click and select the corresponding router network you want to configure.
- ⑥ Input the password of wireless network, (note the case difference), Tap “Connect”.
- ⑦ If connected successfully “Connection succeeded” will displayed. After successful configure, the indicator status of WIFI module will be steady on.

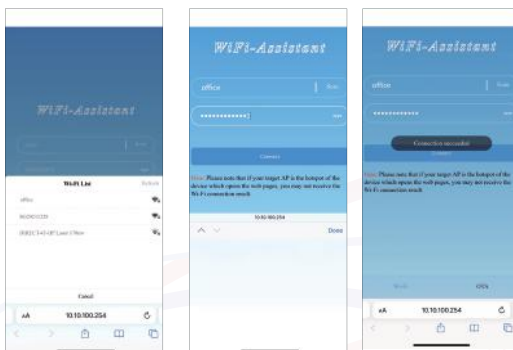

8 Appendix

8.1 Technical Parameters

Model	RMM-MA	RMK-MA	RMM-5A	RMK-5A
Signal and power input				
Voltage	230/400V,3~			
Frequency	50~60 Hz			
Current	100mA		5A	
Current overload	Continue: 1.2 times; instantaneous: 2times / 10			
Voltage input impedance	>1MΩ			
Accuracy				
Current/Voltage	0.5%			
Frequency	±0.01Hz			
Active Power	Class 0.5S			
Reactive Power	Class 0.5S			
Energy	Class 0.5S			
General data				
Over voltage category	III			
Dielectric strength	Resistance from signal, power supply and output terminal to shell >100MΩ			
Withstand voltage	Input and power supply >1.5kV			
Communication	Modbus RTU (RS485)	Modbus RTU (RS485) WiFi/LAN	Modbus RTU (RS485)	Modbus RTU (RS485) WiFi/LAN
Display	OLED			
Voltage power consumption	<5VA	<7.5VA	<5VA	<7.5VA
Noise Level (dB)	<25	<25	<25	<25
Terminal capacity	0.5~4 mm ²			
Size (L*W*H)	85*54*75mm			
Weight	150g			
Protection class	IP20 (For Indoor Use)			
Installation method	35mm DIN Rail			
Operating temperature	-30 ~ +60°C			
Operating humidity	<95%, No Condensation			
Operating altitude	<3000m			

8.2 Contact Information

Should you have any question about this product, please contact us.

We need the following information to provide you the best assistance:

- Model of the device
- Serial number of the device
- Date of the device
- Fault code/name
- Brief description of the problem

China (HQ)

Solinteg Power Co., Ltd.

Address: Building H1-1001, No. 6 Jingxian Road, Xinwu District, 214135

Wuxi, Jiangsu Province, China

Website: www.solinteg.com

Service Mail: service@solinteg.com

INTEGRATE SOLAR INTELLIGENTLY



www.solinteg.com



M11-00026-01